

## Submersible pump for waste water with solids in suspension, grinder system

### Applications

Evacuation, transfer and emptying of waste water with solids in suspension.

### Materials

Pump and impeller in cast iron.  
Grinder blade in steel.  
Pump shaft in AISI 420.  
Mechanical seal.  
O-rings in NBR.

### Equipment

90° elbow included.  
Model MA: float switch and 10m of cable without plug.  
Model M/T: without float switch and 10m of cable without plug.  
External capacitor with capacitor box included.

### Motor

Asynchronous 2 poles.  
IP68 protection.  
Class F insulation.  
Single phase motor with built-in thermal protection.  
Continuous operation.

### Limitations

Maximum water temperature: 40° C.  
Maximum submersion: 7m.



### Hydraulic performance table

Model	I [A]			P1 [kW]		P2		c [μF] 220V	l/min m³/h	50	100	150	200	250	Code		
	1~ 220V	*3~ 220V	*3~ 440V	1~	3~	[kW]	[HP]								1~220V (Model MA)	*3~220V (Model T)	*3~440V (Model T)
Draincor 180	8	4,7	2,7	1,7	1,6	1,1	1,5	16+40	mwc	3	6	9	12	15	96612	96606	96608
Draincor 200	8,9	5,4	3,1	1,9	1,8	1,3	1,7	25+50		21	19	16	12	7	96619	96614	96616

### Performance curve at 3450 rpm

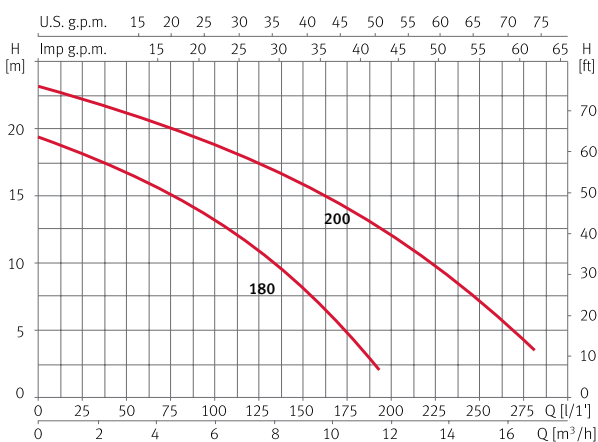

### Dimension and weight

Model	A	B	C	D	E	F	G	H	I	Kg
Draincor 180	115	125	383	415	119	196	92	110	1 1/2"	25
Draincor 200	115	125	383	415	119	196	92	110	1 1/2"	25

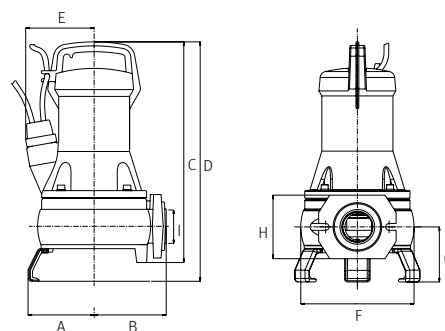

\* See ESPA voltages page 70

## Portable version

A	B	C	D	E	F	G	H	I	J	K	L	M
437	338	110	219	62	95	49	98	98	134	110	55	55

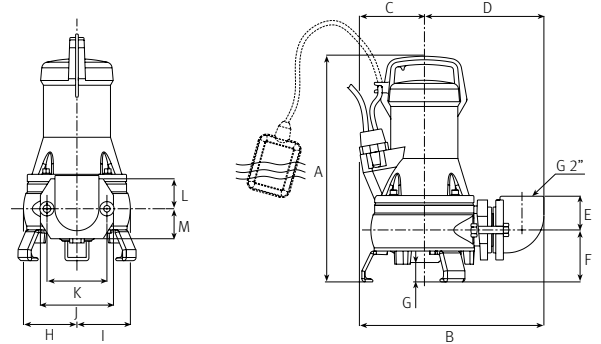

## Stationary version

A	B	C	D	E	F	G	H	I	J	K	L	M
388	353	110	168	60	112	60	52	8	12	51	∅10	24

N	O	P	Q	R	S	T	U	V	W	X	Y	Z
209	∅25	85	∅10	98	98	120	94	12	40	13	32	60

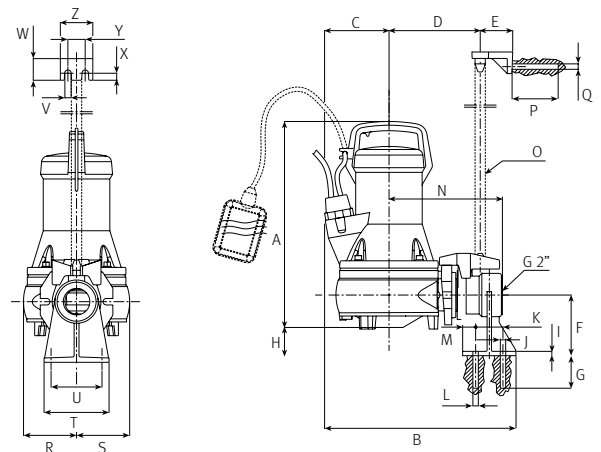

# Accessories Drainex and Draincor Drainage



## Installation kit for Drainex 200/300/400/500/600 and Draincor 180/200

### Stationary version for Drainex 200 and Draincor 180/200



Support base for automatic anchoring



Clamping flange



Upper anchoring on guide tube

Kit	Code
DR1	100527

### Stationary version for Drainex 300



Support base for automatic anchoring



Clamping flange



Upper anchoring on guide tube

Kit	Code
DR2	100528

### Stationary version for Drainex 400/500

DN65 (flange 65)



Support base with elbow for automatic anchoring

DIN 2501 PN16



Clamping flange

ANSI 150 2"



Upper anchoring on double guide tube

Kit	Code
DR3.2	207381

### Portable version for Drainex 400/500



90° elbow at 2"



Stainless steel feet

Kit	Code
DR6	132139
DR6 NPT	151472

### Stationary version for Drainex 600

DN65 (flange 65)



Support base with elbow for automatic anchoring

DIN 2501 PN16



Clamping flange

ANSI 150 2 1/2"



Upper anchoring on double guide tube

Kit	Code
DR4.2	207379

### Portable version for Drainex 600



90° elbow at 2 1/2"



Stainless steel feet

Kit	Code
DR7	132140
DR7 NPT	151473